

MS3

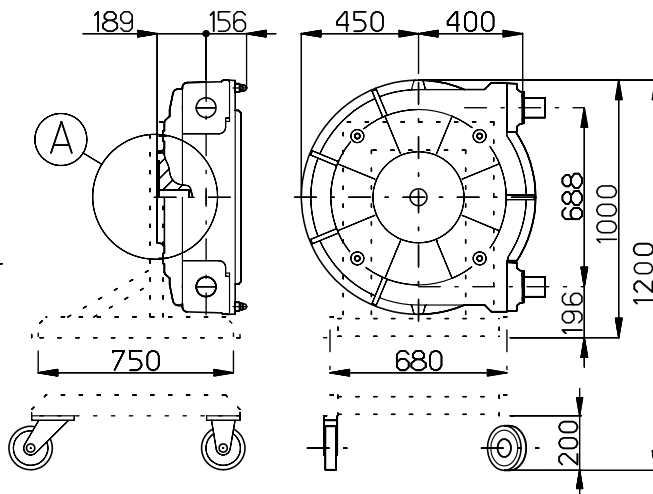

- Welding conn. Ø 76,1
- Flange DIN Dn 65
- Flange ANSI 2" 1/2
- Dn 65
DIN 11851
- Threaded BSP 2" 1/2

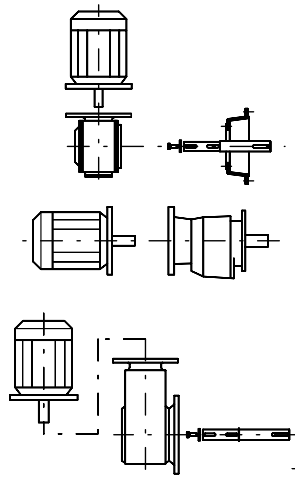
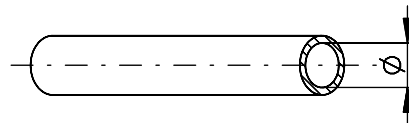
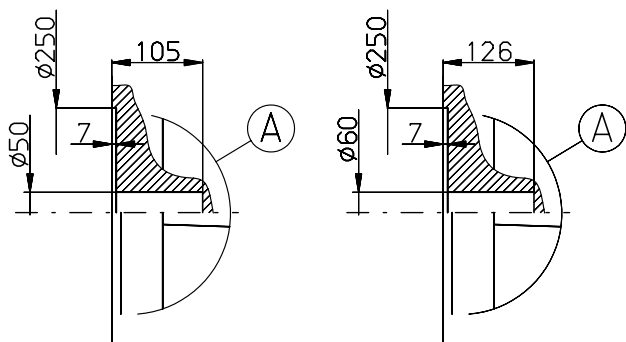

TECHNICAL DATA			
MOD.	Ø mm	LT/RPM	MAX BAR
MS3	68	6,80	8-15

0-4 bar					
RPM	Lt/h	BAR		Kw	
		std	max		
14	5372	2	4	2,2	
15	5773	2	4	2,2	
17	6576	2	4	2,2	
19	7378	2	4	2,2	
21	8180	2	4	3	
24	9384	2	4	3	
26	10186	2	4	3	
29	11390	2	4	4	
32	12594	2	4	4	
39	15402	2	4	5,5	
42	16606	2	4	5,5	
51	20216	2	4	7,5	
56	22222	2	4	7,5	
63	25031	2	3	7,5	
71	28240	2	3	7,5	
79	31450	2	2	7,5	

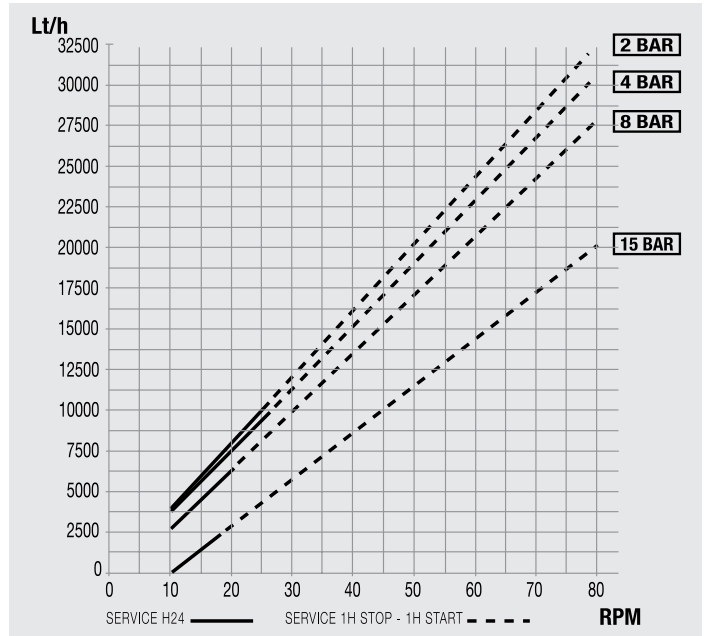

4-8 bar				
RPM	Lt/h	BAR		Kw
		std	max	
14	5258	4	8	3
15	5651	4	8	3
17	6437	4	8	4
19	7223	4	8	4
21	8009	4	8	4
24	9188	4	8	5,5
26	9974	4	8	5,5
29	11153	4	8	7,5
32	12332	4	8	7,5
39	15084	4	6	7,5
42	16263	4	6	7,5
51	19800	4	5	7,5
56	21765	4	4	7,5
63	24517	4	3	7,5
71	27661	4	3	7,5
79	30805	4	2	7,5

variable gear speed 0-4 bar						
RPM		Lt/h		BAR		Kw
max	min	max	min	std	max	
10	1,8	3767	477	2	4	2,2
11	2,1	4168	598	2	4	2,2
12	2,3	4570	678	2	4	2,2
13	2,6	4971	798	2	4	2,2
15	2,8	5773	879	2	4	2,2
17	3,2	6576	1039	2	4	4
19	3,6	7378	1200	2	4	4
21	4	8180	1360	2	4	4
23	4,4	8983	1520	2	4	4
28	5,3	10989	1882	2	4	4
30	5,8	11791	2082	2	4	7,5
36	6,9	14198	2523	2	4	7,5
40	7,7	15803	2844	2	4	7,5
45	8,5	17809	3165	2	4	7,5
51	9,7	20216	3647	2	4	7,5
56	10,7	22222	4048	2	4	7,5
63	11,9	25031	4529	2	3	7,5

8-10 bar				
RPM	Lt/h	BAR		Kw
		std	max	
13	3706	8	10	4
16	4787	8	10	4
17	5148	8	10	5,5
20	6229	8	10	5,5
21	6589	8	10	5,5
25	8031	8	10	7,5
27	8752	8	10	7,5
31	10193	8	10	11
34	11274	8	10	11

variable gear speed 4-8 bar						
RPM		Lt/h		BAR		Kw
max	min	max	min	std	max	
10	1,8	3930	707	4	8	4
11	2,2	4323	865	4	8	4
12	2,3	4716	904	4	8	4
14	2,7	5503	1061	4	8	4
15	2,9	5896	1140	4	8	4
18	3,4	7075	1336	4	8	7,5
19	3,6	7468	1415	4	8	7,5
22	4,3	8647	1690	4	8	7,5
24	4,6	9433	1808	4	8	7,5
29	5,5	11398	2162	4	8	9,2
36	6,9	14149	2712	4	6	9,2
44	8,3	17294	3262	4	6	9,2

15 bar				
RPM	Lt/h	BAR		Kw
		std	max	
13	758	15	15	7,5
16	1625	15	15	7,5
18	2203	15	15	7,5
19	2492	15	15	7,5
22	3359	15	15	11
26	4515	15	15	11
31	5960	15	12	11

variable gear speed 6-10 bar						
RPM		Lt/h		BAR		Kw
max	min	max	min	std	max	
10	1,8	3550	438	6	10	4
11	2,2	3929	590	6	10	4
12	2,3	4308	628	6	10	4
14	2,7	5067	780	6	10	5,5
15	2,9	5447	856	6	10	5,5
18	3,4	6585	1045	6	10	7,5
19	3,6	6965	1121	6	10	7,5
22	4,3	8103	1387	6	10	7,5
24	4,6	8862	1501	6	10	7,5
29	5,5	10759	1842	6	8	9,2
36	6,9	13415	2373	6	8	9,2
44	8,3	16451	2905	6	6	9,2