

DF190

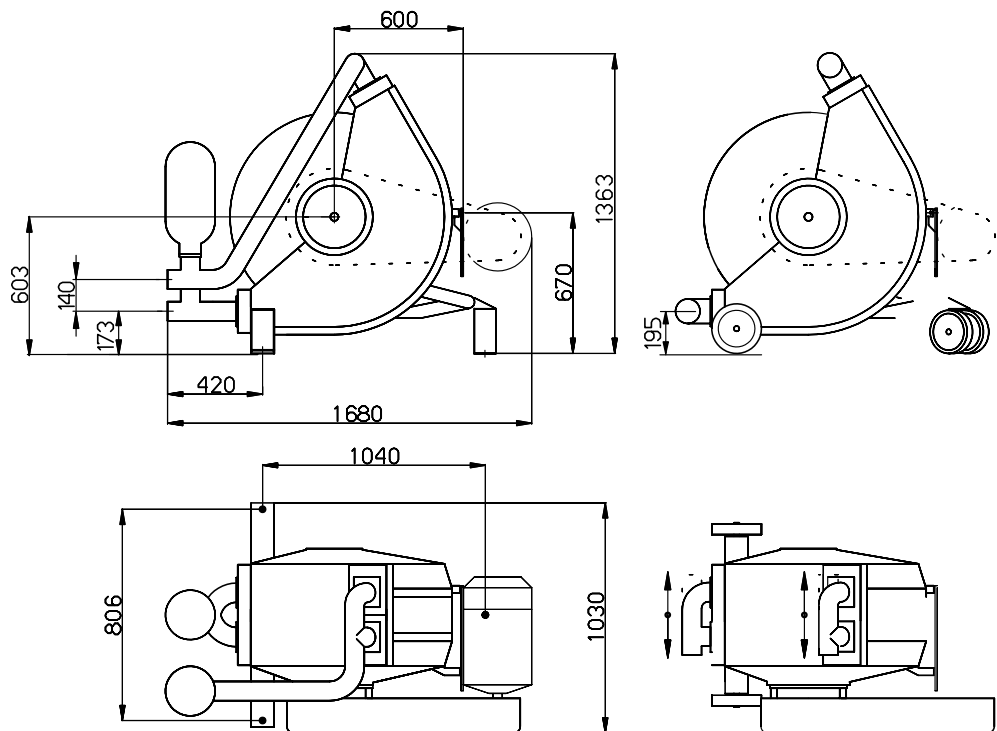

Welding conn. Ø 101
 Flange DIN Dn 100
 Flange ANSI 4"
 Dn 100
 DIN 11851
 Threaded BSP 4"



TECHNICAL DATA			
MOD.	Ø mm	LT/RPM	MAX BAR
DF	90	29	8

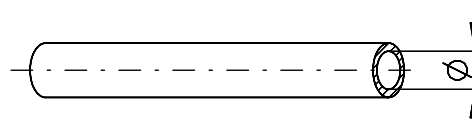

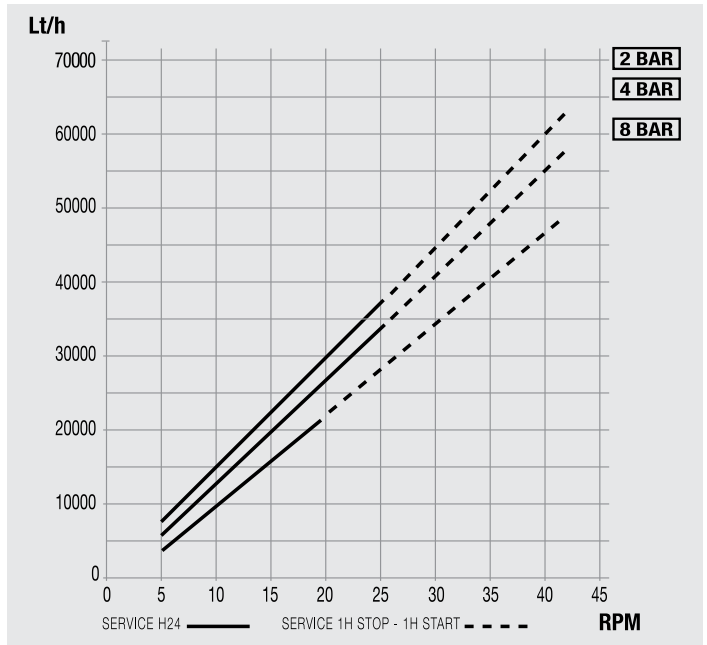

0-4 bar				
RPM	Lt/h	BAR		Kw
		std	max	
16,9	26598	2	4	11
18,8	29624	2	4	11
21,4	33766	2	4	11
23,9	37749	2	4	11
26,8	42368	2	4	11
30,1	47625	2	3	11
33,6	53201	2	2,5	11
37,6	59573	2	2,5	15
41,8	66263	2	2,5	15

4-6 bar				
RPM	Lt/h	BAR		Kw
		std	max	
16,9	26050	4	6	11
18,8	29015	4	6	11
21,4	33073	4	6	15
23,9	36974	4	6	15
26,8	41500	4	6	18,5
30,1	46650	4	6	18,5
33,6	52112	4	5	18,5
37,6	58355	4	5	22
41,8	64909	4	4	22

6 bar				
RPM	Lt/h	BAR		Kw
		std	max	
16,9	24166	6	6	11
18,8	27028	6	6	11
21,4	30945	6	6	15
23,9	34712	6	6	15
26,8	39081	6	6	18,5
30,1	44053	6	6	18,5
33,6	49326	6	5	18,5
37,6	55352	6	5	22